

# JUXTA F Series Instruction Manual

Model FH3A/V  
Hi-Speed Isolator

JUXTA

## 1. INSPECTION

This instrument has been thoroughly tested at the factory before shipment. When you receive it, visually inspect it for damage and check the accessories.

### 1.1 Model number and specification check

Check to see the model number and specifications on the nameplate attached to the front cover of the transmitter are as ordered.

### 1.2 Contents of the instruction manual

This instruction manual provides instructions on how to mount, wire externally and maintenance of the instrument.

## 2. GENERAL

This instrument receives current or voltage signals and converts them into isolated current or voltage signals.

Accessories: Mounting block	2
Tag number label	1
Mounting screw M	2

## 3. MOUNTING METHOD

JUXTA signal conditioners can be mounted on racks, walls or DIN rails.

### 3.1 Rack mounting

Use panel (FRK-16) and install the instrument on an angle as shown in Fig.1. This is a convenient method for high density mounting on 19-inch rack panel. (See Fig. 7.)

### 3.2 Wall mounting

Use panel (FRK-16) to install the instrument on the wall as shown in Fig. 2 or directly mount it on the wall. (See Figs. 7 and 8 for mounting dimensions.)

### 3.3 DIN rail mounting

Insert a DIN rail into the upper section of the DIN rail groove on the rear of the instrument and lock the rail in position by using the slide lock at the base of the instrument as shown in Figs. 3 and 4.

### 3.4 Angle mounting

If the instrument is mounted without using the panel (FRK-16), refer to Fig. 5 for its mounting.

### 3.5 Mounting block installation and removal

Insert a mounting block into groove of the instrument and slide it until it locks in position by the stopper as shown in Fig.6. To remove it, use screwdriver to lift the stopper and slide the mounting block along the groove.

## 4. EXTERNAL WIRING

Open the terminal cover of the instrument and wire the terminal. Flexible twisted wire and good contact of durable round crimp-on terminals (JIS C2805) are recommended to be used.

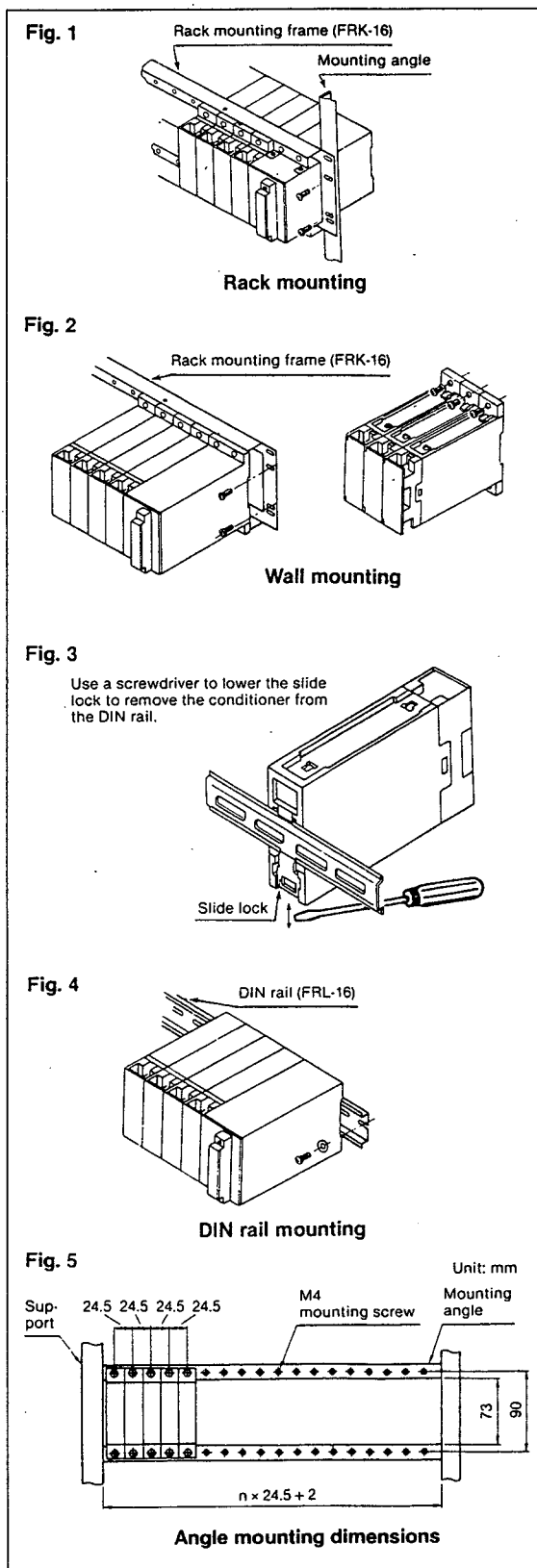

#### 4.1 Signal cable

Nominal cross-sectional area of conductor:  
0.5 to 0.75 mm<sup>2</sup>

Example of suitable cable:  
Twisted vinyl cord (VSF) (JIS C3306)

#### 4.2 Power cable

Nominal cross-sectional area of conductor:  
1.25 to 2.00 mm<sup>2</sup>

Example of suitable cable:  
Twisted 600V vinyl cord (IV) (JIS C3307)

#### 4.3 Wiring

- ① See Fig. 9 for the terminal arrangement.
- ② Connect input voltage signal cable to transmitter terminals 2(+), 3(-).
- ③ Connect transmitter output signal cable to its terminals 4(+) and 5(-).
- ④ Connect 24V DC power supply to transmitter terminals 6(+), 7(-). (See Fig.10)

### 5. ITEMS TO BE CHECKED BEFORE TURNING THE POWER SWITCH ON

- ① Make sure that 24V DC power supply of the transmitter is connected to the correct polarities.
  - ② Confirm that the external wiring to the terminal board is correct.
  - ③ Check that the mounting, ambient temperature, humidity, dust and vibration are normal.
- Confirm the above items before turning the power switch. The transmitter needs 5 minutes warm-up to satisfy its specified accuracy.

### 6. MAINTENANCE

(Caution)

Carry out the following calibration after warm-up the transmitter for more than 5 minutes.

#### 6.1 Equipment required for calibration

- Voltage/current generator  
(Yokogawa Model 2553 or equivalent) 1
- Voltmeter  
(Yokogawa Model 2502A or equivalent) 1
- Precision resistor, 250Ω ±0.01%, 1W 1  
(in case of current output)

#### 6.2 Calibration

- ① Connect each equipment as shown in Fig. 11.
- ② Input/output characteristic check  
Use voltage/current generator and apply input signals equivalent to 0%, 25%, 50%, 75%, 100% of input span. Check that the corresponding output signals are 0%, 25%, 50%, 75%, 100% of output span respectively and are within ±1% of specified accuracy rating range.  
\*If an output signal is out of tolerance, adjust it by span and zero adjustment trimmers on front panel of the instrument.

Fig. 6

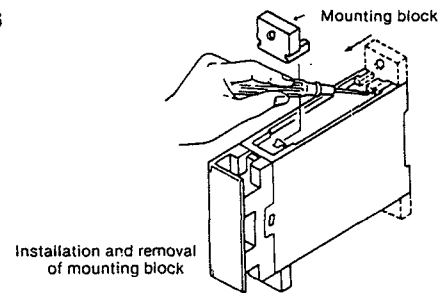

Fig. 7

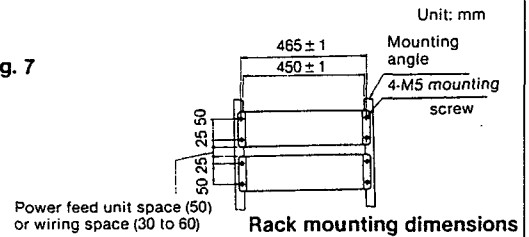

Fig. 8

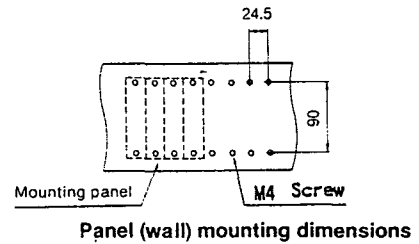

Fig. 9

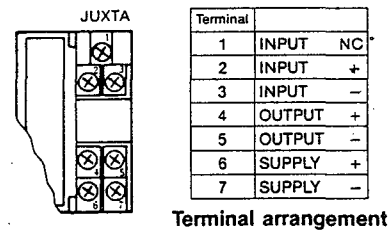

Fig. 10

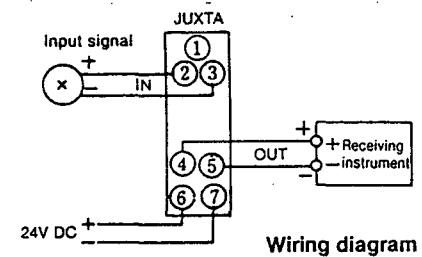
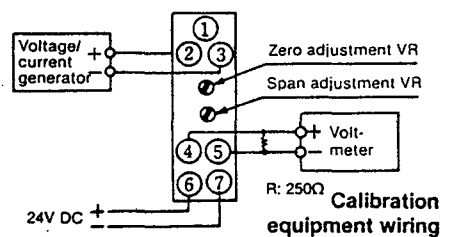

Fig. 11



Subject to change without notice for grade up quality and performance.